

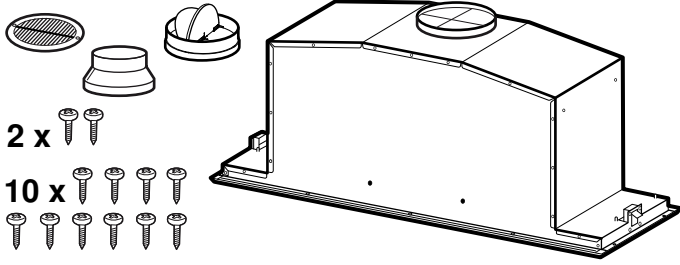

9001018801 970426

en Installation instructions



 **BUY NOW**

# A

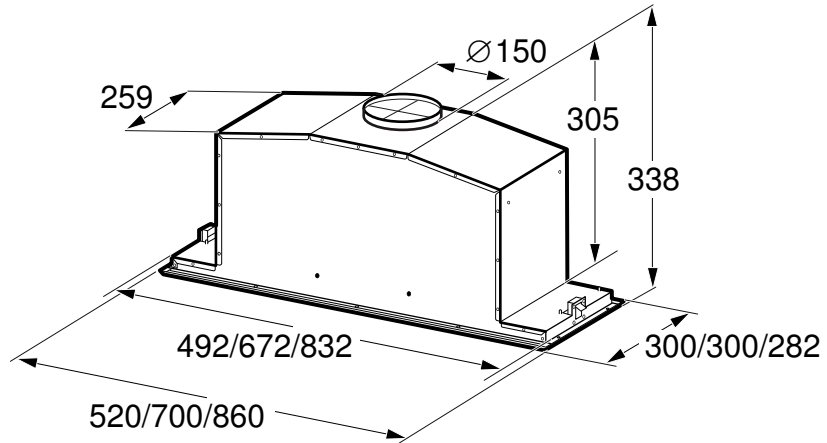

# B

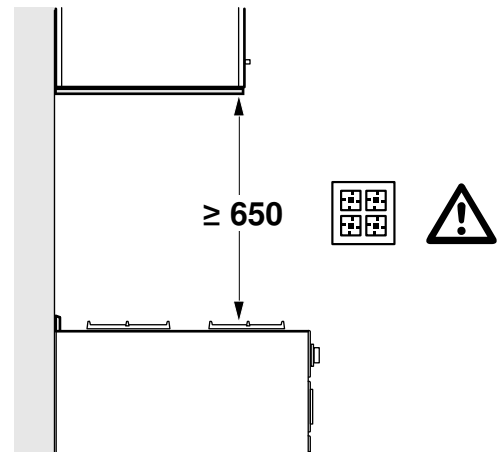
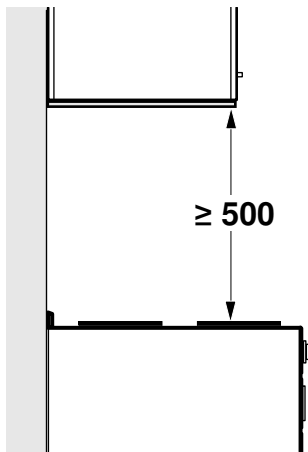

# 1a

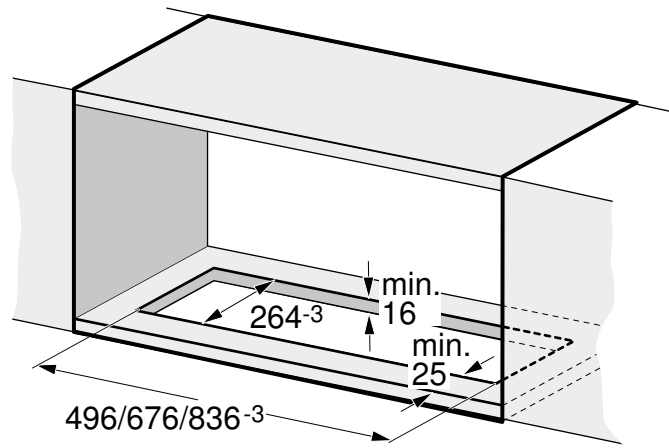

# 1b

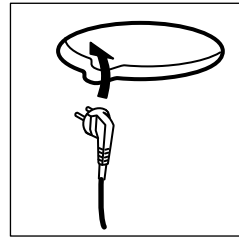
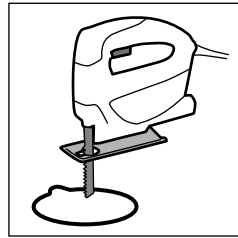
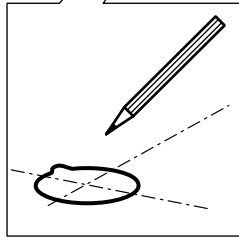
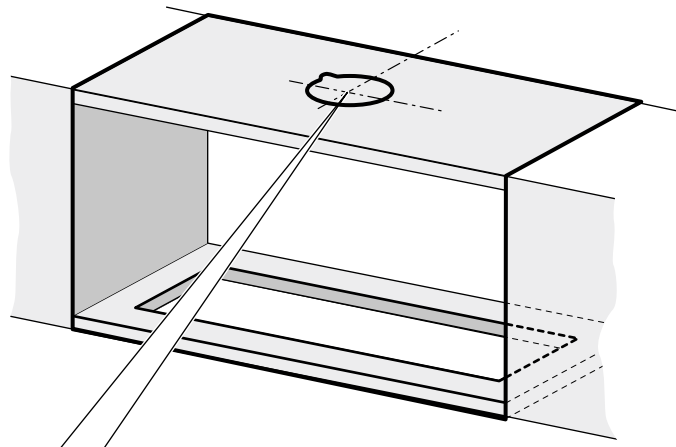
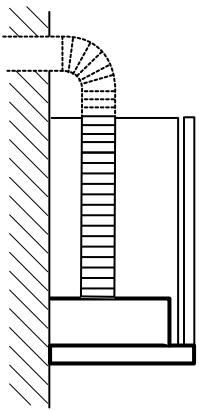

# 1c

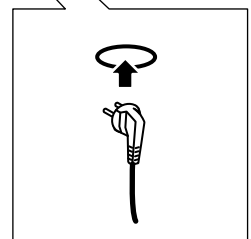
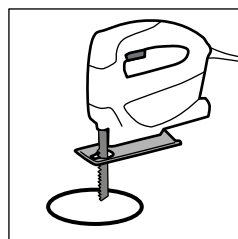
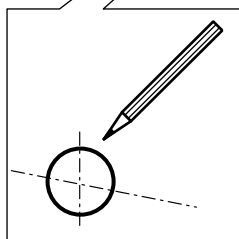
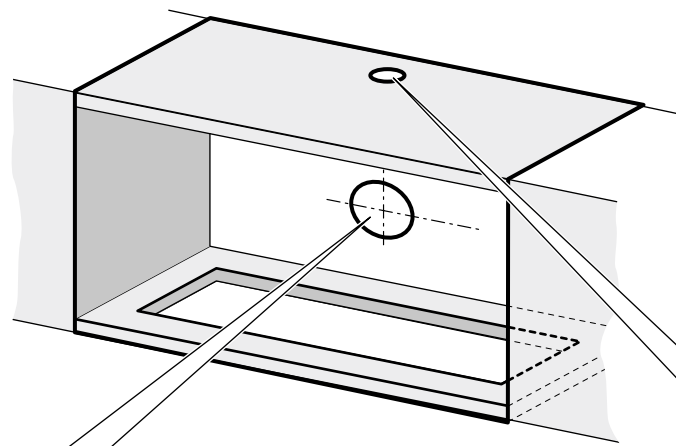
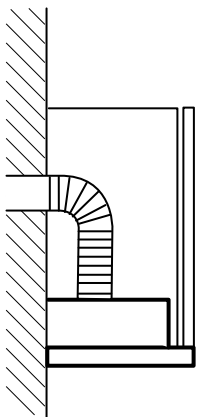

**2a**

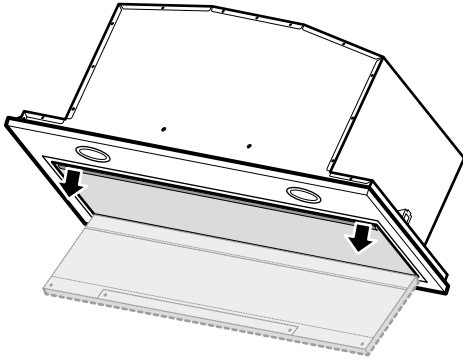

**2b**

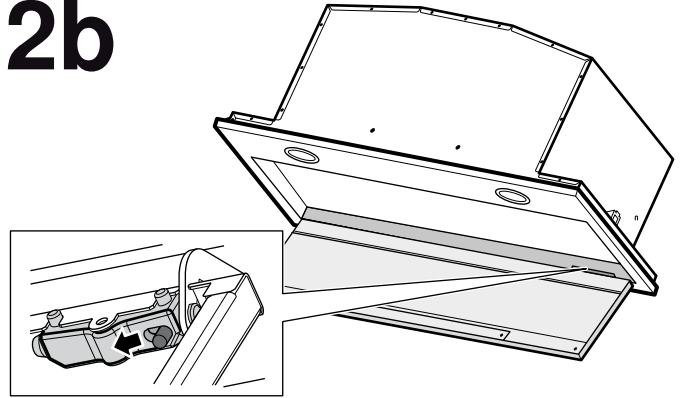

**2c**

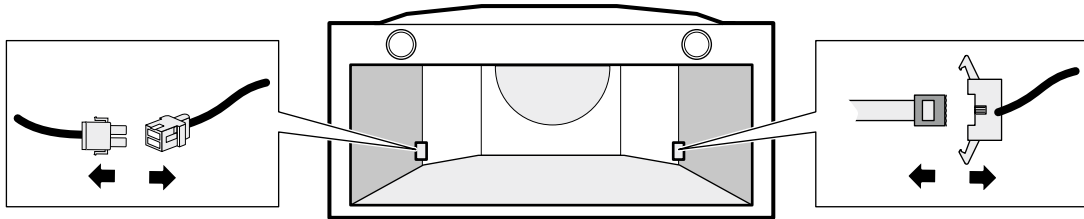

**2d**

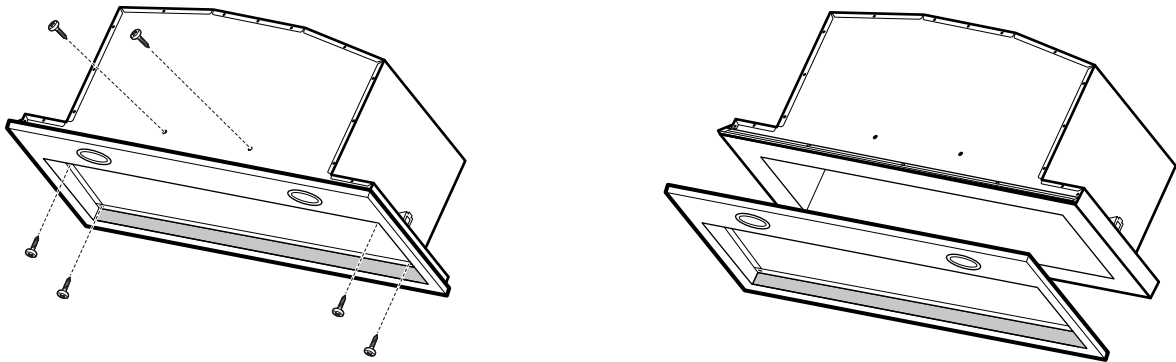

**2e**

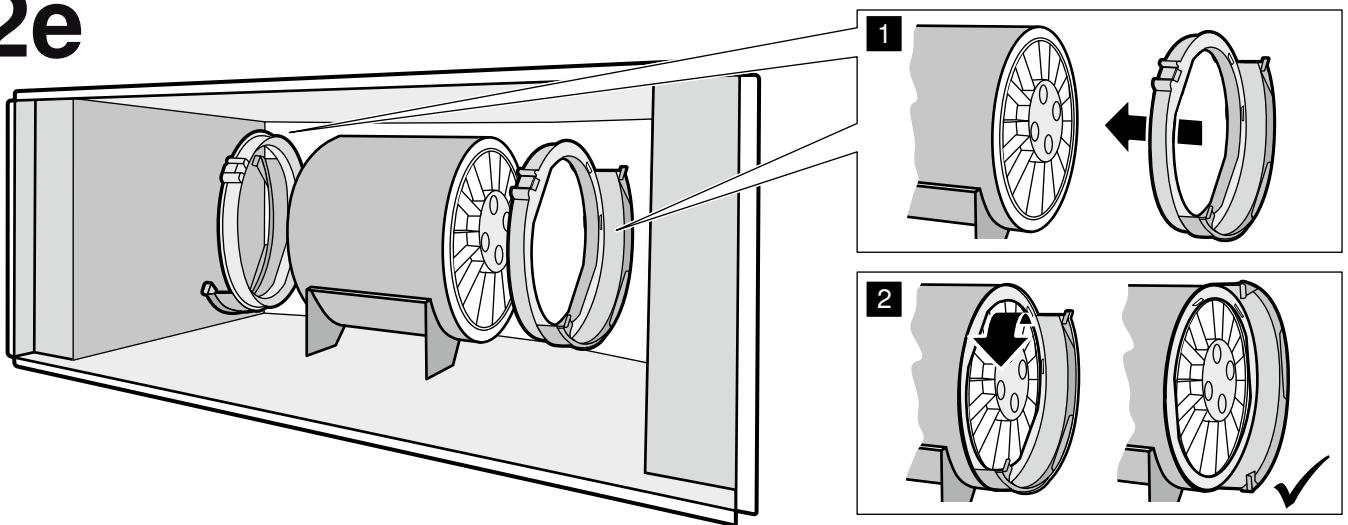

**3a**

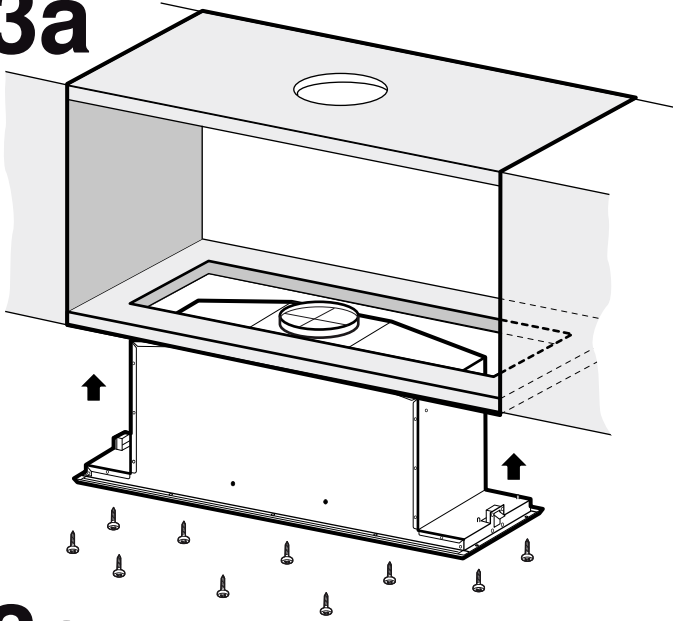

**3b**

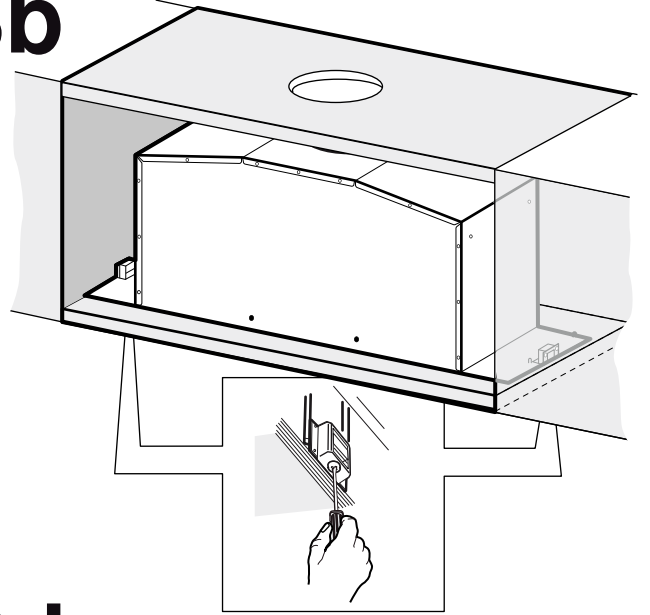

**3c**

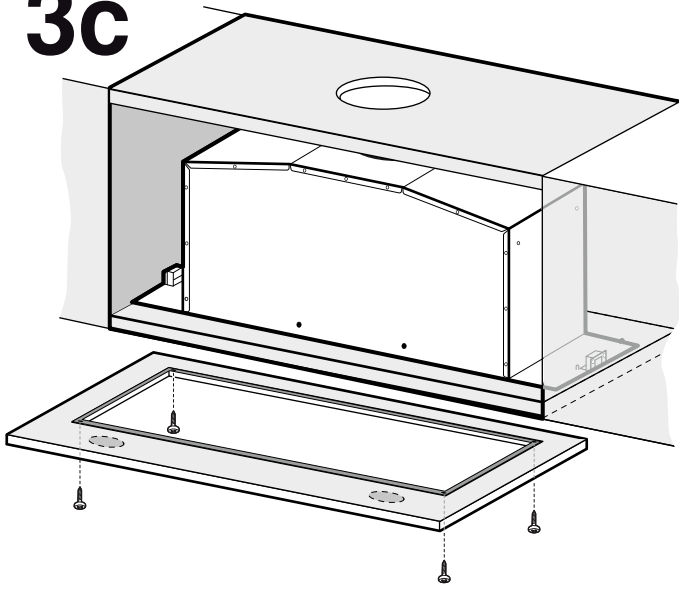

**3d**

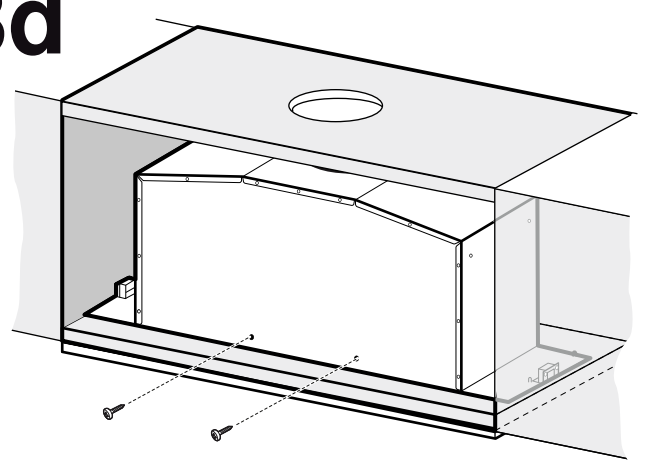

**4a**

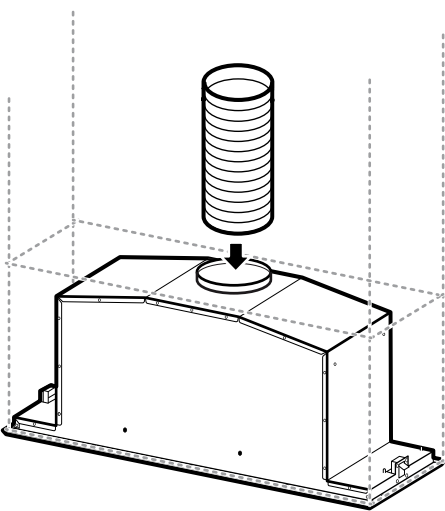

**4b**

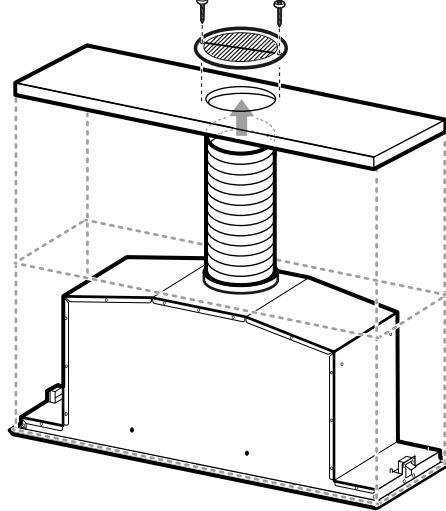

**4c**

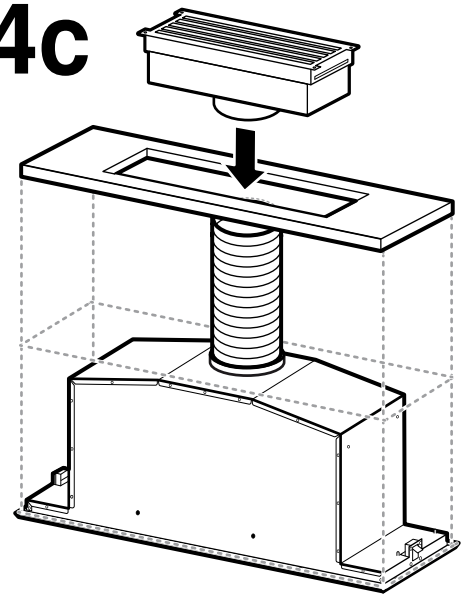

## ⚠ Important safety information

Read these instructions carefully. Only then will you be able to operate your appliance safely and correctly. Retain the instruction manual and installation instructions for future use or for subsequent owners.

Check the appliance for damage after unpacking it. Do not connect the appliance if it has been damaged in transport.

The appliance can only be used safely if it is correctly installed according to the safety instructions. The installer is responsible for ensuring that the appliance works perfectly at its installation location.

The width of the extractor hood must correspond at least with the width of the hob.

For the installation, observe the currently valid building regulations and the regulations of the local electricity and gas suppliers.

When conveying the exhaust air, official and legal regulations (e.g. state building regulations) must be followed.

### Danger of death!

Risk of poisoning from flue gases that are drawn back in.

Always ensure adequate fresh air in the room if the appliance is being operated in exhaust air mode at the same time as room air-dependent heat-producing appliance is being operated.

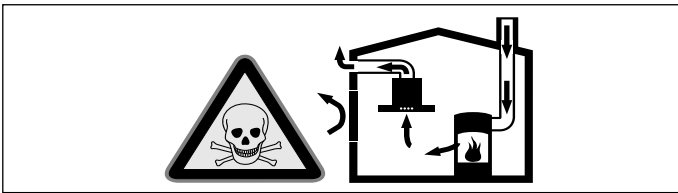

Room air-dependent heat-producing appliances (e.g. gas, oil, wood or coal-operated heaters, continuous flow heaters or water heaters) obtain combustion air from the room in which they are installed and discharge the exhaust gases into the open air through an exhaust gas system (e.g. a chimney).

In combination with an activated vapour extractor hood, room air is extracted from the kitchen and neighbouring rooms - a partial vacuum is produced if not enough fresh air is supplied. Toxic gases from the chimney or the extraction shaft are sucked back into the living space.

- Adequate incoming air must therefore always be ensured.
- An incoming/exhaust air wall box alone will not ensure compliance with the limit.

Safe operation is possible only when the partial vacuum in the place where the heat-producing appliance is installed does not exceed 4 Pa (0.04 mbar). This can be achieved when the air needed for combustion is able to enter through openings that cannot be sealed, for example in doors, windows, incoming/exhaust air wall boxes or by other technical means.

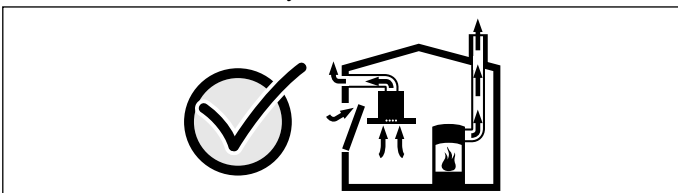

In any case, consult your responsible Master Chimney Sweep. He is able to assess the house's entire ventilation setup and will suggest the suitable ventilation measures to you.

Unrestricted operation is possible if the vapour extractor hood is operated exclusively in the circulating-air mode.

### Risk of death!

Risk of poisoning from flue gases that are drawn back in. The exhaust air must not be conveyed into a functioning smoke or exhaust gas flue or into a shaft which is used to ventilate installation rooms that contain heating appliances. If the exhaust air is to be conveyed into a non-functioning smoke or exhaust gas flue, you must obtain the consent of the heating engineer responsible.

### Danger of suffocation!

Packaging material is dangerous to children. Never allow children to play with packaging material.

### Risk of electric shock!

- Components inside the appliance may have sharp edges. These may damage the connecting cable. Do not kink or pinch the connecting cable during installation.
- It must always be possible to disconnect the appliance from the power supply. The appliance must only be connected to a protective contact socket that has been correctly installed. If the plug can no longer be reached after installation, an energy-isolating device in the phases must be provided in the permanent electrical installation in accordance with the installation regulations. The permanent electrical installation must only be wired by a professional electrician. We recommend installing a residual-current circuit breaker (RCCB) in the appliance's power supply circuit.

### Risk of fire!

- Grease deposits in the grease filter may catch fire. The specified safety distances must be observed in order to prevent an accumulation of heat. Observe the specifications for your cooking appliance. If gas burners and electric hotplates are operated together, the largest specified distance applies.
- Grease deposits in the grease filter may catch fire. Never work with naked flames close to the appliance (e.g. flambéing). Do not install the appliance near a heat-producing appliance for solid fuel (e.g. wood or coal) unless a closed, non-removable cover is available. There must be no flying sparks.

### Risk of injury!

- Components inside the appliance may have sharp edges. Wear protective gloves.
- The appliance may fall down if it has not been properly fastened in place. All fastening components must be fixed firmly and securely.
- The appliance is heavy. To move the appliance, 2 people are required. Use only suitable tools and equipment.
- Changes to the electrical or mechanical assembly are dangerous and may lead to malfunctions. Do not make any changes to the electrical or mechanical assembly.

## General information

### Exhaust duct

**Note:** The appliance manufacturer does not provide any warranty for faults attributable to the pipe section.

- The appliance achieves its optimum performance by means of a short, straight exhaust air pipe and as large a pipe diameter as possible.
- As a result of long, rough exhaust air pipes, many pipe bends or pipe diameters that are smaller than 150 mm, the optimum extraction performance is not achieved and fan noise is increased.
- The pipes or hoses for laying the exhaust air line must consist of non-combustible material.
- If the exhaust air is conveyed through the outer wall, a telescopic wall box should be used.

Risk of damage from returning condensate. Install the exhaust duct in such a way that it falls away from the appliance slightly (1° slope).

### Round pipes

An inner diameter of 150 mm, but at least 120 mm, is recommended.

### Flat ducts

The inner cross-section must correspond to the diameter of the round pipes.

**dia. 150 mm ca. 177 cm<sup>2</sup>**

**dia. 120 mm ca. 113 cm<sup>2</sup>**

- Flat ducts should have no sharp deflections.
- Use sealing strip for deviating pipe diameters.

## Electrical connection

### ⚠ Risk of electric shock!

Components inside the appliance may have sharp edges. These may damage the connecting cable. Do not kink or pinch the connecting cable during installation.

The required connection information is on the appliance's identification plate.

This appliance complies with the EC interference suppression regulations.

This appliance must only be connected to a correctly installed earthed socket.

Attach the earthed socket preferably inside the flue duct.

- The earthed socket should be connected via its own circuit.
- If the earthed socket is no longer accessible after installing the appliance, an all-pole isolating switch (e.g. circuit breaker, fuses and contactors) with at least a 3-mm contact gap must be included in the installation.

## Installation preparation

### Checking the fitted unit

- The fitted unit must be level and have sufficient load-bearing capacity.
- The maximum weight of the extractor hood is **10 kg**.

### Appliance dimensions and safety clearances

- Observe the appliance's dimensions. **(Fig. A)**
- Comply with the safety clearances. **(Fig. B)**

If the installation instructions for the gas cooking appliance specify a different distance, the larger of the two must always be provided for.

## Preparing the units

The fitted unit must be heat-resistant up to 90 °C. The fitted unit must still be sturdy after the cut-outs have been made.

After making the cut-outs, remove any shavings.

1. Make the cut-out in the fitted unit. **(Fig. 1a)**
2. Make the cut-out for the exhaust air pipe.

**Note:** You can make the exhaust air opening either above the fitted unit **(Fig. 1b)** or behind the fitted unit **(Fig. 1c)**.

## Preparing the appliance

1. Open the filter cover. **(Fig.2a)**

**Note:** Grasp the front corners of the filter cover and pull it down in a single, swift motion.

2. Undo the hinge lock and remove the filter cover. **(Fig.2b)**
3. Remove the metal grease filter; see the instruction manual.
4. Disconnect the cabling for the control panel and the lighting. **(Fig.2c)**
5. Undo the screws in the frame and remove the frame. **(Fig.2d)**
6. Optional for air recirculation:  
Position the filter retainer (optional accessory) correctly on the motor and turn it to the front until it locks into place. Insert the activated charcoal filter into the filter retainer. **(Fig.2e)**

## Installing the appliance

1. Place the appliance into the opening in the fitted unit and screw it to the fitted unit. **(Fig. 3a)**
2. Tighten the fastening screws. **(Fig. 3b)**
3. Disconnect the cabling for the control panel and the lighting.
4. Put the frame in place and screw it to the appliance from below. **(Fig. 3c)**
5. Secure the frame and the appliance with screws. **(Fig. 3d)**  
**Note:** If the screws are not accessible from the exterior, these can also be fitted from the interior.
6. Insert the metal grease filter.
7. Attach and close the filter cover.

## Connecting the appliance

### Notes

- For exhaust-air operation, a backflow flap should be fitted. If a backflow flap has not been included with the appliance, it can be obtained from a specialist retailer.
- If the exhaust air is conveyed through the outer wall, a telescopic wall box should be used.

### Establishing the connection for the exhaust air **(Fig. 4a)**

**Note:** If an aluminium pipe is used, smooth the connection area beforehand.

1. Attach the exhaust air pipe directly to the air pipe connector.
2. Connect it to the exhaust air opening.
3. Seal the joints appropriately.

### Establishing the connection for the circulated air **(Fig.4b)**

#### Notes

- If an aluminium pipe is used, smooth the connection area beforehand.
  - Fit the air guide grille so that the air can flow out freely.
1. Attach the exhaust air pipe directly to the air pipe connector.
  2. Establish the connection to the opening on the fitted unit.
  3. Screw the air guide grille to the fitted unit.
  4. Seal the joints appropriately.

### Connecting the air recirculation module **(Fig.4c)**

**Note:** If an aluminium pipe is being used, smooth the connection area beforehand.

1. Refer to the printed supplement for the air recirculation module.
2. Attach the exhaust air pipe directly to the air pipe connector.
3. Connect the pipe to the opening on the air recirculation module.
4. Use suitable means to seal the joints.
5. Insert the activated charcoal filter.

### Establishing a connection to the mains

Plug the mains plug into the earthed socket.

## Removing the appliance

1. Disconnect the appliance from the power supply.
2. Disconnect the exhaust air lines.
3. Open the filter cover.
4. Remove the grease filter.
5. Disconnect the cabling for the control panel and the lighting.
6. Remove the frame.
7. Undo the fastening to the fitted unit.
8. Remove the appliance.



